

Systems thinking: critical thinking skills for the 1990s and beyond

Barry Richmond

The problems we face at all levels in the world today resist unilateral solutions. While the web of interdependencies tightens, our capacity for thinking in terms of dynamic interdependencies has not kept pace. As the gap between the nature of our problems and the ability to understand them grows, we face increasing perils on a multitude of fronts. Systems thinking and one of its subsets—system dynamics—are important for developing effective strategies to close this gap. Unfortunately, system dynamicists and systems thinkers have not effectively taught their framework, skills, and technologies to others. The door has not been opened wide enough to let others share our insights with respect to the workings of closed-loop systems. To transfer this understanding on a broad scale, we need a clearer view of its nature and of the education system into which it must be transferred. This article casts some

The problems that we currently face have been stubbornly resistant to solution, particularly unilateral solution. As we are painfully discovering, there is no way to unilaterally solve the problem of carbon dioxide buildup, which is steadily and inexorably raising the temperature around the globe. The problems of crack cocaine, ozone depletion, the proliferation of nuclear armaments, world hunger, poverty and homelessness, rain forest destruction, and political self-determination also fall into the category of "resistant to unilateral solution." Why is it no longer possible for some world power to pull out a big stick and beat a nasty problem into submission? The answer is that it probably never was. It's simply that the connections among the various subsystems conspiring to manifest a problem were less tight. Then, it was possible to score a Pyrrhic victory by essentially pushing a problem off into the future or into "someone else's backyard." Unfortunately, as Dana Meadows is fond of saying, "There is less and less space remaining to throw things away into." *Away* means both space and time. We have less and less space remaining to serve as a receptacle for our "garbage." And we have less and less time before we must endure "the morning after." Both are artifacts of sustained material growth in our finite earthly realm. Every generation of human beings has been subject to these rules, but our generation is the first to have to take them seriously.

System dynamics and systems thinking to the rescue?

If one accepts the argument that the primary source of the growing intractability of our problems is a tightening of the links between the various physical and social subsystems that make up our reality, one will agree that system dynamics and systems thinking hold great promise as approaches for augmenting our solution-generation capacity. The systems thinkers' forte is interdependence. Their specialty is understanding the dynamics generated by systems composed of closed-loop relations. Systems thinkers use diagramming languages to visually depict the feedback structures of these systems. They then use simulation to play out the associated dynamics. These tools give people the ability to "see" a neighbor's backyard—even if that backyard is thousands of miles away. They also confer the ability to "experience" the morning after—even if the morning after is tens of thousands of years hence.

Although the quality of the "seeing" and "experiencing" provided by the current systems thinking tools is improving, these tools remain quite primitive today. In three years, they will be much less so. In ten, available tools will be capable of effectively compressing space and time so as to produce "virtual

light on what we have to bestow and on the education system that is to receive our bounty. Its intended audience is both system thinkers and educators, and the hope is to help eradicate the distinction between the two.

Barry Richmond is managing director and founder of High Performance Systems, an organization providing software and consulting services to build the capacity of people to understand and improve the workings of dynamic systems. Dr. Richmond is the impetus behind the iThink and STELLA II modeling and simulation software packages. He has taught at Thayer School of Engineering, Dartmouth College, and holds a Ph.D. degree in system dynamics from Sloan School of Management, MIT, and degrees from Syracuse, Columbia, and Case Western Reserve universities. Address: High Performance Systems, 45 Lyme Rd., Hanover, NH 03755, U.S.A.

realities." In these electronic realities, people will be able to participate in creating powerful, visceral experiences for themselves. But, no matter how advanced the technology gets, it will always be only part of the solution. If people are to make sense of their experiences in virtual realities, they must have the capacity for understanding the underlying closed-loop framework that is generating these experiences. They must be capable of thinking both systemically and dynamically. In short, they must be systems thinkers. This, in turn, brings us back to a long-unanswered question, which has plagued system dynamics from its outset some 30 years ago at that venerable technical university on the Charles River in Cambridge, Massachusetts. The question is, How can the framework, the process, and the technologies of systems thinking be transferred to the rest of the world in an amount of time that is considerably less than what it currently takes to get a master's or Ph.D. degree in our field?

I will argue that to successfully answer this question it is necessary to confront two aspects of the transfer process. We first must better understand the evolution of the education system into which the transfer must be made (this system offers the best potential for large-scale transfer). Second, we must better understand the "thing" we are seeking to transfer. Specifically, we must understand that this "thing" is multifaceted. As such, for people to swallow and digest it, it must be broken down into more consumable pieces.

Aspect 1: the evolution of the education system

Like any viable system, our system of formal education is evolving over time. The last several decades have seen numerous innovative experiments in educational progress and technology. Open classrooms, computer-aided instruction, and interdisciplinary course offerings are but a few of the initiatives that have been and are being tried. It is my perception that the time is now ripe for three evolutionary threads to come together to form a new learning gestalt. The three threads, illustrated in Figure 1, are educational process, thinking paradigm, and learning tools. The evolutionary fusing of these three threads can successfully create a permanent change in the way people learn. The evolution of each thread, taken independently, cannot.

Thread 1: educational process

I will refer to the newly emerging educational process as *learner-directed learning*. I like this phrase because it positions the process in sharp relief against the process that has dominated teaching for at least the last 200 years: *teacher-directed learning*.

Fig. 1. Three evolutionary threads in education

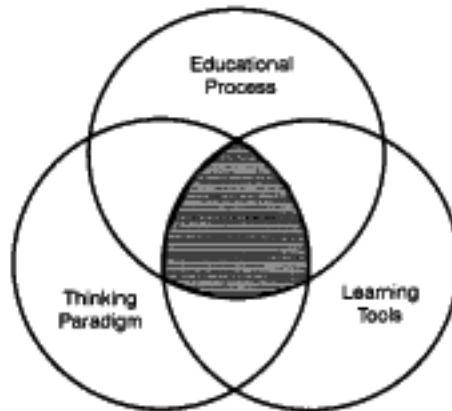

We are all, to varying degrees, products of a teacher-directed learning process. In this process, the classroom is arranged with students facing the front, in rows or nested U's. At the front is "Herr Professor." Herr Professor's job is to transmit what he or she knows to the students. The student's job is to take in as much of this transmission as possible. This is why it is important for students to "be quiet and pay attention" in the classroom. A schematic representation of the teacher-directed learning process appears at the left in Figure 2.

It is important to reveal the implicit assumption about learning that underlies a teacher-directed learning process. It is that learning is primarily an assimilation process. This assumption, in turn, defines appropriate roles for both teacher and student. Teacher is transmitter, or content dispenser. Student is receiver, or content receptacle. The objective of the educational process, then, is for the teacher to "fill up" the student. Measuring performance in this system is straightforward. Simply ask the student to retransmit what has previously been transmitted by the teacher. If the student can "dump" a full load, he is performing well. It's interesting to note that the teacher-directed learning process tacitly assumes that the students do not have much to contribute to each other's learning experience. Otherwise, they would not be arrayed in a physical arrangement in which they face the back of each other's heads.

Contrast the teacher-directed learning process with a learner-directed approach, illustrated at the right in Figure 2. The learner-directed approach assumes that learning is fundamentally a construction rather than an assimilation process. This means that to learn the student must reconstruct what is being taken in. Meaning and understanding are "making" processes, not "imbibing" processes. Extending this assumption leads to the conclusion that because there are many strategies for "making," learning cannot be standardized. People construct in different ways, at different paces, and in different

Fig. 2. Teacher-directed and learner-directed learning processes

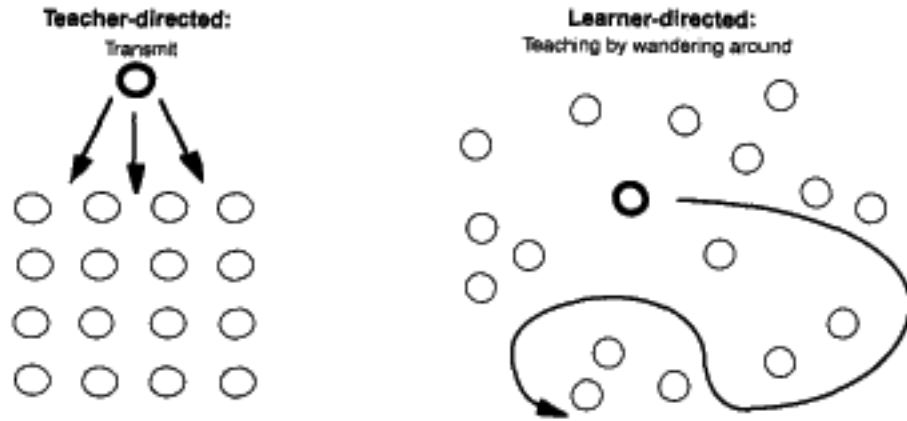

sequences. Construction also is an active process. Being quiet and listening often can be antithetical to construction activities. Both teacher and learner, in this process, have new roles. Teacher now is charged with providing materials and alternative strategies for constructing. In a sense, she creates the building environment. Once the building process begins, she wanders around, playing the role of project manager, keeping the process on track, but not doing the construction. Students are the construction workers. And, like construction crews, they often can accomplish more, reaping more enjoyment in the process, by working in teams rather than alone.

In order for a learner-directed approach to work, it is essential that both teachers and students rethink their roles and respective contributions to the learning process. Teachers must be willing to abdicate their position as all-knowing fonts of knowledge and wisdom. Students, in turn, must be willing to take personal responsibility for their learning. Students must also learn to cooperate with each other as learning partners rather than viewing fellow students as competitors in a zero-sum game. These are easy words to write, but the shifts in perspective and process needed to bring these changes about are quite profound. Fortunately, the benefits that appear to be achievable—from looking at the results of some experiments in several learner-directed processes—promise to be equally profound.

To begin with, the age-old question, Why do we have to learn this? is likely to cease reverberating through our schools. The active learning process will provide an outlet for the inherent need that all human beings have for activity. The cooperation involved will model the very processes needed to live in an increasingly interdependent world community. And all these gains can be achieved with no necessary forfeiture of content assimilation, because when students can see the "why," content assimilation becomes a means to an end

Fig. 3.
Overpopulation
laundry list



rather than an end in itself. There are thus many "free lunches" to be eaten here. We have only to avail ourselves of the opportunity. Availing, however, will require not only the profound shifts in role, administrative structure, and performance measurement already alluded to but also that the two other threads—thinking paradigm and learning tools—also come together.

Thread 2: thinking paradigm

It is very difficult to see what you use for seeing. But that's what is involved in confronting your thinking paradigm. It's the water you swim in, so pervasive it's completely transparent. To bring it into view, try answering the following question: What is causing the overpopulation problem in so many countries in the world today? Take a moment to jot down a few thoughts before proceeding.

If you took the time to record your thoughts, I'll bet they took the form of a list. If you reflect on the structure of the mental modeling process that generated this "laundry list," I think you'll find that it looks something like Figure 3.

I like to refer to the mental modeling process that produces such lists as laundry list thinking. I believe it to be the dominant thinking paradigm in most of the Western world today. If one asks most Westerners (and many Easterners, too) a "what causes what?" type of question, one is likely to get a laundry list of causal factors in response. Implicitly, people also weight each factor in the list: this one is most important, this one is second and so on. This kind of mental modeling has been given analytical expression as a multiple regression equation. Many of us are familiar with this type of expression:

$$y = a_0 + a_1X_1 + a_2X_2 + \dots + a_nX_n$$

where

y = dependent variable

X_i = independent variables

a_i = coefficients (or weighting factors) for each of the independent variables

Notice that the implicit assumptions in the laundry list thinking process are that (1) each factor contributes as a cause to the effect, i.e., causality runs one way; (2) each factor acts independently; (3) the weighting factor of each is fixed;

Fig. 4.
Overpopulation
feedback loop



and (4) the way in which each factor works to cause the effect is left implicit (represented only by the sign of the coefficients, i.e., this factor has a positive or a negative influence).

The systems thinking paradigm offers alternatives to each of these assumptions. First, according to this paradigm, each of the causes is linked in a circular process to both the effect and to each of the other causes. Systems thinkers refer to such circular processes as feedback loops. Figure 4 illustrates two such loops. The shift from one-way to circular causality, and from independent factors to interdependent relations, is a profound one. In effect, it is a shift from viewing the world as a set of static, stimulus-response relations to viewing it as an ongoing, interdependent, self-sustaining, dynamic process. It will also cause students to think in a very different way about what is going on in the world around them.

The third assumption implicit in the laundry list paradigm is that factors have a static weighting. By contrast, in the systems thinking view, as Figure 4 suggests, the strength of the closed-loop relations is assumed to wax and wane over time. Some loops will dominate at first, other loops will then take over, and so on. Therefore, addressing a problem is not seen as a one-shot deal. Rather, it is considered necessary to think in terms of ongoing, interdependent relations whose strengths vary over time, partly in response to interventions that may have been implemented into the system.

The final assumption associated with laundry list thinking is that correlation is good enough for explaining how a system works. The systems thinking paradigm challenges this regression analysis approach, offering in its place operational models of how things work. Thus, for someone steeped in the systems thinking paradigm, it would not be enough to identify the factors that are correlated with overpopulation. Instead, it would be necessary to actually offer an operational explanation of how overpopulation is generated. The contrast between the correlational and operational models of the overpopulation process is illustrated in Figures 5 and 6.

The systems thinking paradigm, when combined with the learner-directed learning process, will breed students who are hungry to understand how things really work and who will continually be looking for how these workings might

Fig. 5. A correlational model

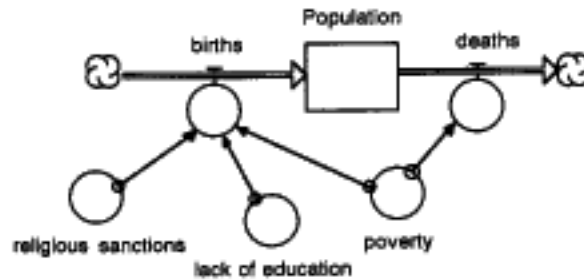
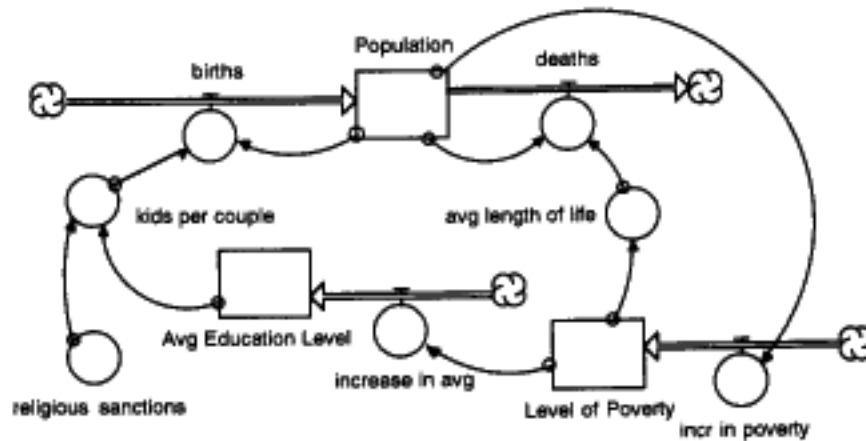

Fig. 6. An operational model



change over time as a consequence of shifts in the relative strengths of the underlying dynamic relations.

Thread 3: learning tools

To fully meld a learner-directed learning process with the systems thinking paradigm, it is essential to have the right set of learning tools available for classroom and out-of-classroom use. The tools of a teacher-directed, laundry list learning process—textbooks and blackboards—will play a smaller role in a nontransmit, active learning process. Textbooks operate, in effect, as purveyors of silent lectures. Students read them, for the most part, for the same reason they currently go to class—to assimilate content. On blackboards teachers can chart static relations and display lists. However, blackboards are not well suited to analyzing a system's dynamics. To support an inquiry-oriented, learner-directed learning process, textbooks and blackboards must share the stage with an emerging tool: the personal computer. The personal computer, with its rapidly expanding sound and graphic animation capabilities, holds the

potential for compressing space and time. As such, these devices can serve as personal theaters in which virtual realities can be played out. Students literally can have the experience of wandering around in both space and time, stashing content that has been embedded in appropriate nooks in the electronics-based learning environment into their intellectual knapsacks as they go. And the content need not be limited to unadorned statements of fact. Video segments, sounds, animation, puzzles, and all other forms of intellectually stimulating presentations are fair game. What's more, the students' wandering need not be choreographed by the teacher. Both the pace and sequence of discovery can be led to the control of the individual learner or group of learners.

In order to elevate a learning environment above the status of a video game, it is essential that it enable learners to understand why things happen. Without this, the interplay between learner and computer can too easily deteriorate into "beat the machine." It is encouraging to see that even with today's relatively primitive software tools (Richmond et al. 1987; Peterson 1990), a few truly excellent learning environments have been created and are now in use (Draper and Swanson 1990; Peterson 1990). And the software tools are improving (see, e.g., Diehl 1990). The results have been extremely promising. Students who had previously "gotten off the bus," tended to get back on. The opportunity to design something (like a mammal, a state park, or a policy for managing an ecosystem) in a learning environment seemed to reset the counters, giving all students a chance to succeed once again. Motivation was high, and hence disciplinary issues for the most part evaporated. Students assimilated content at higher rates, in some cases doing research on their own in order to be able to do a better job in their design project. At the same time, depth of understanding of the concepts increased, and students' capacity for critical thinking was enhanced. Students began to think in terms of the long-run, as well as the immediate, implications of their decisions and actions. They began to anticipate the second- and third-order effects of their choices.

These results suggest what is possible when a new learning gestalt comes together. But even when all three threads—educational process, thinking paradigm, and learning tools—are ripe for fusion within a particular educational setting, there remains the issue of how to equip teachers with an understanding of the framework, processes, and technologies of systems thinking. Let's begin by emphasizing that it is not reasonable to expect teachers, on a wide scale, to stop what they're doing and move en masse to one or more of the institutions of higher learning that offer formal degrees in system dynamics. Teachers, like most other people, are very busy. And many could not secure the financial resources even if they did have the time. Furthermore, there is not sufficient system dynamics teaching capacity to process such demand. What, then, can be done to facilitate the fusion process when things are ready to fuse?

Aspect 2: transferring the systems thinking framework, process, and tools

I taught system dynamics in the Thayer School of Engineering at Dartmouth College for nine years. During this time, I experienced considerable frustration at the fact that after three or more courses even the good master's student ("good," in this case, being a pretty select breed!) often encountered considerable difficulty in constructing and analyzing a model from scratch come thesis time. This being the case, what hope was there, I used to muse, for any widespread dissemination of systems thinking?

Since leaving Dartmouth three years ago, my colleagues and I at High Performance Systems have embarked upon a mission designed to answer the question, Just how far is it possible to go in cutting the up-to-speed time for the serious, yet not whiz-bang, pilgrim? Now, after offering more than 50 workshops for educators, business folk, and all manner in between—both in the United States and abroad—I do believe that I can say, pretty far! In recent workshops, after two-and-a-half days, participants had produced models from scratch that addressed issues of their own choosing. The models were initialized in steady state, had been subjected to a rigorous testing program to establish robustness, and in many cases did a credible job of replicating the observed behavior pattern of interest. The quality of the better models in terms of "tightness" and insight-generation capacity was equivalent to what I used to receive from a good master's thesis effort. How was this achieved?

First, over the three-year period, we carefully monitored performance and continually fed back the results. We maintained no attachment to what we had done in previous workshops. Indeed, we turned over our curriculum materials at least 50 times each (and continue to do so). My intention here is not to summarize this closed-loop evolutionary process. Instead, I wish to stand back from the process and to focus on what we discovered to be the most fundamental barrier to learning productivity. Simply stated, it is cognitive overload.

What has become apparent over the course of the last three years of workshops is that doing good systems thinking means operating on at least seven thinking tracks simultaneously. This would be difficult even if these tracks were familiar ways of thinking. But they are not. And the result in the majority of cases is cognitive overload. Nevertheless, we've found that it is possible to take certain steps to prevent people from becoming overloaded. Specifically, (1) tell people that they're going to be asked to juggle multiple thinking tracks simultaneously; (2) be explicit about what these tracks are; and (3) align the curricular progression to emphasize development of only one thinking skill at a time.

It helps to begin placing the seven systems thinking skills into a broader

Fig. 7. Critical thinking skills the systems thinking

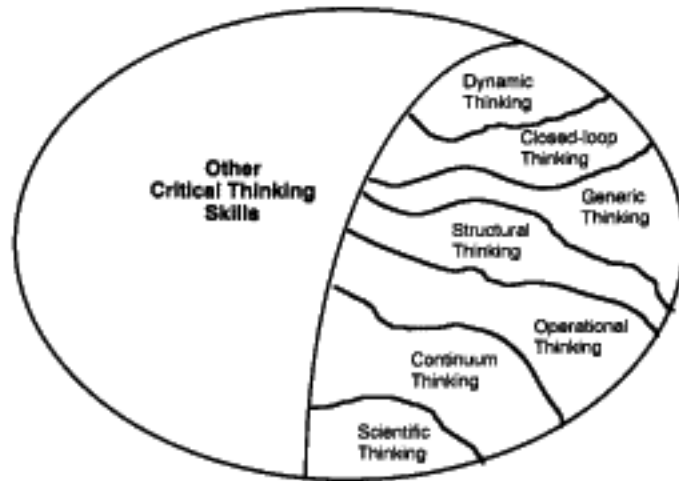

context. That context in education seems most appropriately labeled critical thinking skills. The seven tracks that I would construe as constituting systems thinking skills are depicted in Figure 7.

Skill 1: dynamic thinking

Dynamic thinking is the ability to see and deduce behavior patterns rather than focusing on, and seeking to predict, events. It's thinking about phenomena as resulting from ongoing circular processes unfolding through time rather than as belonging to a set of factors. Dynamic thinking skills are honed by having to trace out patterns of behavior that change over time and by thinking through the underlying closed-loop processes that are cycling to produce particular events. Having students think about everyday events or newspaper stories in terms of *graphs over time* would be good exercises for developing their abilities to think dynamically. Also very helpful is the use of simple models in real-time exercises in which students are asked to hypothesize what behavior pattern will result when a particular system is disturbed in a particular way. As an illustration of this kind of exercise, consider the simple system depicted in Figure 8.

In this system, mature trees are harvested. Each time a mature tree is removed via harvesting, a sapling is instantaneously planted to replace it. Saplings take exactly six time periods to pass through the Maturation Pipeline (entering the Mature Trees stock). All saplings mature (none die, all germinate). Given these structural assumptions, next assume the system is initially in steady state. This means that (1) mature trees are being harvested at the same rate that they're

Fig. 8. Maturation pipeline structure

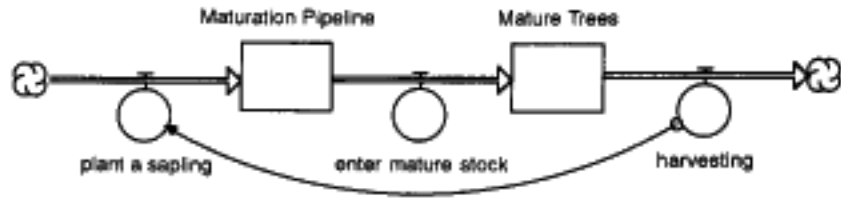
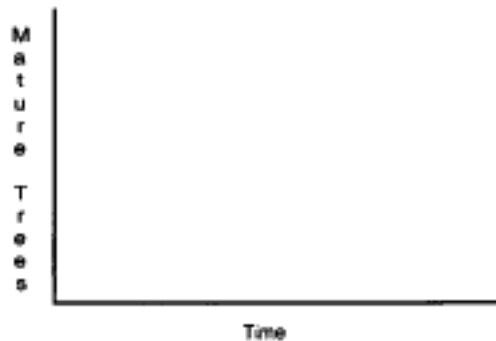

Fig. 9. Pattern of behavior



being planted (by definition, this is true), and (2) that the maturation pipeline is primed up such that trees are entering the Mature Trees stock at the same rate. Thus, both the stock of Mature Trees and the number of trees in the Maturation Pipeline are constant. Now, suppose that the harvest rate suddenly steps up to a new higher level and then remains there forever. What pattern do you think the stock of Mature Trees will trace over time in response to this permanent step increase in the harvest rate? Sketch your guess on the axis provided in Figure 9.

In our experience, with widely diverse audiences (across education level, occupation, age, and culture), only about 20 percent of people who guess at the answer guess correctly. This says something about the level of our dynamic thinking skills. It also says something about the potential for an extremely fruitful union of computer and human. Computers could never construct, or "understand," the preceding illustration. However, 100 percent of the computer population will correctly deduce the dynamic pattern of behavior that the Mature Trees stock will trace in response to the step increase in the harvest rate. Combining the human being's ability for making meaningful structure with the computer's ability for correctly tracing out the dynamic behavior patterns implied by that structure holds great promise for leveraging our capacity for addressing the set of intractable problems mentioned at the beginning of this article.

The correct answer to this illustration, by the way, is that the Mature Trees

stock will decline linearly for six time periods. It will then level off and remain at this lower level forever. If you are having trouble understanding why this is true, I suggest that you trace out the pattern charted by each of the three flows in the system following the step increase in harvesting. Then think about what will happen to the Mature Trees stock when this pattern of flow unfolds.

Skill 2: closed-loop thinking

The second type of thinking process, closed-loop thinking, is closely linked to the first, dynamic thinking. As already noted, when people think in terms of closed loops, they see the world as a set of ongoing, interdependent processes rather than as a laundry list of one-way relations between a group of factors and a phenomenon that these factors are causing. But there is more. When exercising closed-loop thinking, people will look to the loops themselves (i.e., the circular cause-effect relations) as being responsible for generating the behavior patterns exhibited by a system. This is in contrast to holding some set of external forces responsible: external forces tend to be viewed as precipitators rather than as causes. They are considered to be capable of calling forth the behavior patterns that are latent within the feedback-loop structure of a system but not of causing these behaviors (in the sense of shaping their essential characteristics). This is a subtle, but extremely important, shift in viewpoint. It coincides, at the level of the individual, with adoption of an internal locus of responsibility. Such an adoption leads people to ask, How am I responsible for what transpired? rather than Why am I always the one who has it done to me? Making the system itself the cause of its behaviors, rather than a set of external forces places the burden of improving performance on relations that those within the system can manage. This perspective stands in sharp contrast to bemoaning "the slings and arrows of outrageous fortune."

There are numerous exercises available to build skill in identifying and representing the feedback-loop structure of a system as well as in viewing the dynamic behavior exhibited by that system as caused by its structure. See, e.g. Roberts et al. (1983) and Richmond et al. (1987).

Skill 3: generic thinking

Just as most people are captivated by events, they are generally locked into thinking in terms of specifics. Thus, for example, Gorbachev is seen as the man who brought glasnost and perestroika to the former Soviet Union. He's also the man who has allowed "freedom" to emerge in many of the former Soviet satellites. But is Gorbachev responsible, or was "freedom" an idea whose time had come? Similarly, was it Hitler, Napoleon, Joan of Arc, Martin Luther King who

determined changes in history, or tides in history that swept these figures along on their crests? The notion of thinking generically rather than specifically applies not only to history. Apprehending the similarities in the underlying feedback-loop relations that generate a predator-prey cycle, a manic-depressive swing, the oscillation in an L-C circuit, and a business cycle can demonstrate how generic thinking can be applied to virtually any arena.

To develop generic thinking skills, people can work with a series of generic structures that progress from simple exponential growth and decay, through S-shaped growth, to overshoot/collapse and oscillation (Richmond et al. 1987). They also can do exercises with the classic policy insensitivity structures, e.g., Shifting the Burden to the Intervener, Floating Goal, First Response in the Wrong Direction, and Promotion Chain (Richmond 1985; Meadows 1982).

Skill 4: structural thinking

Structural thinking is one of the most disciplined of the systems thinking tracks. It's here that people must think in terms of units of measure, or dimensions. Physical conservation laws are rigorously adhered to in this domain. The distinction between a stock and a flow is emphasized. To catch a glimmer of the kind of skill being developed here, consider the simple causal-loop diagram in Figure 10. The notion here is simple and intuitive, and it would work pretty well if one were proceeding along the dynamic thinking track. Beginning with births, the diagram says simply that as births increase, population increases. And, as population increases, births follow suit. This is a simple positive feedback-loop process. Left unchecked, it will generate an exponential increase in population over time.

When the same two variables are represented using a structural diagram (Fig. 11), a subtle but important dynamic distinction becomes apparent. The same positive feedback process depicted in Figure 10 is shown here, and again we see that if births increase, population follows suit.

Now, however, return to the causal-loop diagram (Fig. 10) and run the thought experiment in reverse. That is, begin by *decreasing* births. According to the causal-loop diagram, a decrease in births would result in a decrease in population. Clearly, this is not necessarily true. Population would only decrease following a decrease in births if births fell to a level *below* deaths. The causal-loop diagram, a tool for engaging in dynamic thinking, is not well suited to structural thinking (Richardson 1982). That's why the structural diagram was invented. As the structural diagram in Figure 11 shows, a decrease in births will only serve to slow the rate at which population is increasing. When one engages in structural thinking, such subtle distinctions (which can be very important in understanding dynamics) must be made.

Fig. 10.
Population
feedback loop



Fig. 11.
Population
structural
diagram

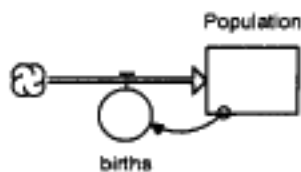

Another simple example will further illustrate the rigor associated with the structural thinking track. Consider the diagram in Figure 12, which provides an intuitive but structurally incorrect representation of a simple conveyor line process. Empty bottles flow along a conveyor, enter a filling station, and are filled with liquid that drains out of a vat. Filled bottles then exit the station and accumulate in a filled bottle inventory. Simple, intuitive and, as I said, not structurally correct.

To see why, examine the alternative representation of the process in Figure 13. In this alternative representation, notice that the flow of liquid and the flow of bottles are kept distinct. This is not the case in the first, more intuitive representation. If one took a snapshot of the actual process, the photograph would more closely resemble Figure 12. After all, liquid really does pour into bottles. However, liquid and bottle do not become one. We still have liquid (measured in liters) and bottles (measured in number of bottles). So, from a units-of-measure standpoint, we still have two quantities: number of bottles and number of liters. If one mixed the two units of measure, one would end up with a very strange quantity in the box labeled "Bottles being Filled," namely, bottle-liters .

When engaging in structural thinking, it is essential to maintain units-of-measure integrity within each stock-and-flow subsystem. Imprecise notions like "I put a lot of effort into the project" and "I'll give you all my love" simply "don't compute" when doing structural thinking. Quantities that flow into a stock must have the same units of measure as that stock. Maintaining unit integrity ensures the conservation of physical quantities. This, in turn, keeps one from getting something for nothing. It also infuses a very strong discipline and precision into the thinking process.

Fig. 12.
Intuitive,
structurally
incorrect
representation

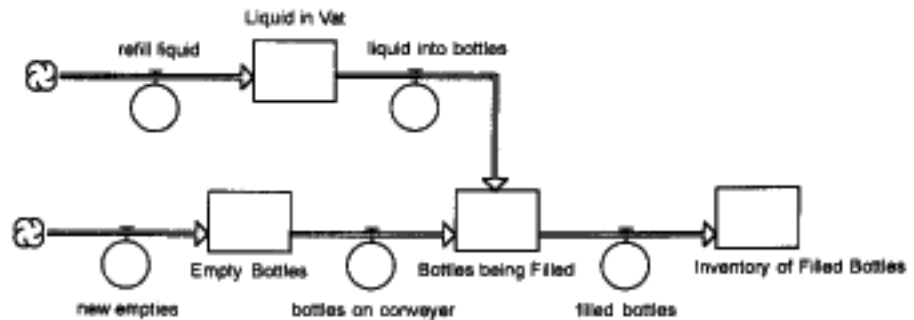
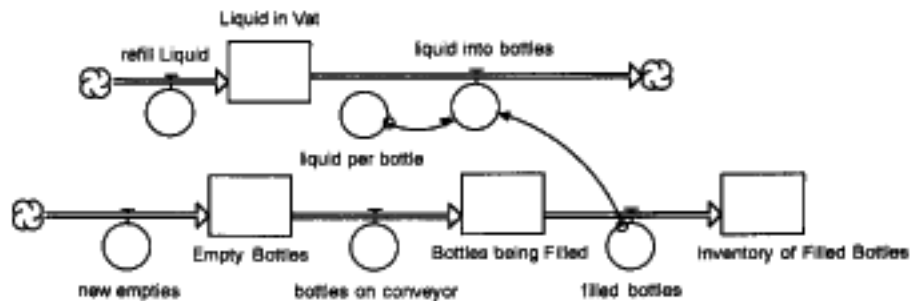

Fig. 13.
Structurally
correct: using
distinct units of
measure



Skill 5: operational thinking

Operational thinking goes hand in hand with structural thinking. Thinking operationally means thinking in terms of how things really work—not how they theoretically work, or how one might fashion a bit of algebra capable of generating realistic-looking output. One of my favorite examples of the distinction between operational and nonoperational thinking is provided by the "universal soil loss equation." This equation expresses a "fundamental law" in soil physics. Used to predict the volume of erosion that will occur on a given parcel of land, it can be represented as

$$\text{Erosion} = \text{RKLSCP}$$

where

- R = rainfall
- K = soil erodability
- L = slope length
- S = slope gradient
- C = vegetative coverage
- P = erosion control practices

Fig. 14.
Operational
Thinking: how it
really works

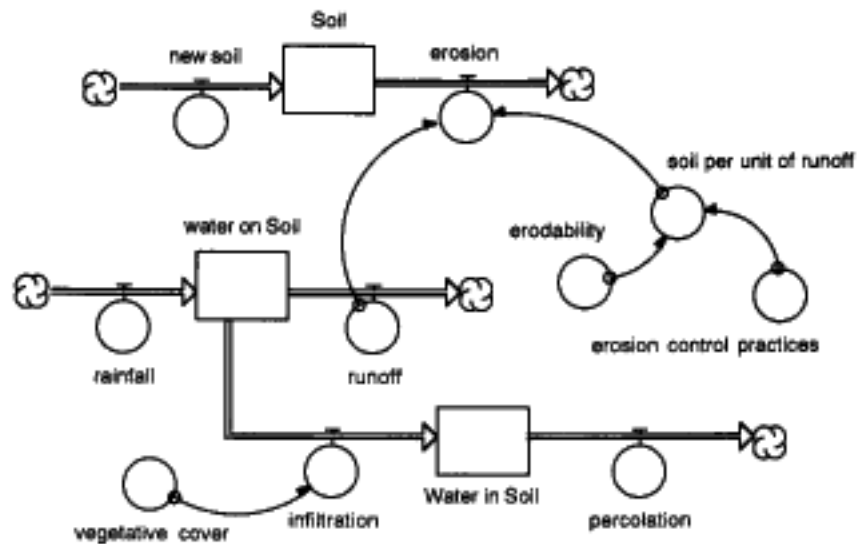

Now, no self-respecting soil particle solves this equation before it rolls on down the hill! In fact, the erosion process—if one wanted to see how it really works—probably would look more like Figure 14.

As the figure indicates, erosion is a process, not a string of factors. It is generated by water running off, with each unit of runoff carrying with it a certain quantity of soil. That quantity is, among other things, influenced by erosion control practices and by the characteristics of the soil itself. By looking at erosion in an operational way, it becomes possible to think more effectively about what the real levers are for managing the process.

A second brief example should further illustrate the notion of operational thinking. A popular economic journal published the research of a noted economist who had developed a very sophisticated econometric model designed to predict milk production in the United States. The model contained a raft of macroeconomic variables woven together in a set of complex equations. But nowhere in that model did cows appear. If one asks how milk is actually generated, one discovers that cows are absolutely essential to the process. Thinking operationally about milk production, one would focus first on cows, then on the rhythms associated with farmers' decisions to increase and decrease herd size, the relations governing milk productivity per cow, and so on.

Operational thinking grounds students in reality. It also tends to be perceived as relevant because the student is thinking about it *like it really is* rather than dealing with abstractions that may bear little relation to what's going on. It's

easy to create exercises that develop operational thinking. Simply look around at real-world processes (like learning, becoming friends, experiencing peer pressure, pollution, drug or alcohol addiction) and ask, How do these processes really work? Let the students diagram their resulting observations. Then have them challenge each other's depictions, asking, is this really how it works?

Skill 6: continuum thinking

Continuum thinking is nourished primarily by working with simulation models that have been built using a continuous, as opposed to discrete, modeling approach. Discrete models are distinguished by containing many "if, then, else" type of equations. In such models, for example, one might find that water consumption (the outflow from Available Water) is governed by some logic of the form IF Available Water >0 THEN Normal Water Consumption ELSE 0. The continuous version of this relation would begin with an operational specification of the water consumption process (e.g., Water consumption = Population × Water per person). Water per person (per year) then would be a continuous function of Available Water.

Unlike its discrete analog, the continuous formulation indicates that water consumption would be continuously affected as Available Water became depleted. That is, measures such as rationing, increases in water prices, or moratoriums on new construction would come into play as residents of the area began to detect less than adequate supplies of water. The discrete formulation, by contrast, implies "business as usual" right up to the point where Available Water falls to zero. At that point, consumption is zero. Although, from a mechanical standpoint, the differences between the continuous and discrete formulations may seem unimportant, the associated implications for thinking are quite profound.

An "if, then, else" view of the world tends to lead to "us versus them" and "*is* versus *is not*" distinctions. Such distinctions, in turn, tend to result in polarized thinking. Issues are seen as black or white; gray is not an option. Two examples should help make this point.

In the early 1970s, a Stanford University psychologist, Philip Zimbardo, conducted a now infamous experiment in which he randomly divided a group of undergraduate Stanford males into two groups. The first he classed as "prisoners," the second as "guards." The two groups, with little other direction, were told to "play prison" for a couple of weeks. Within two days, a student who had assumed the role of prisoner broke down and had to be released. The experiment was terminated prematurely (after six days) because two other "prisoners" had broken down, and others appeared to be on the verge of doing the same. In the postmortem discussion and analysis, one of the students was identified as having played the role of a "John Wayne" guard. He

had shown considerable ingenuity in his forms of degradation and punishment. An interesting question was posed: if "John Wayne" could have been screened out before the experiment, would the results have been the same? Was the unexpectedly high level of brutality attributable to the tone being set by this one student guard?

From an "if, then, else" viewpoint, one might answer yes: screen out any "John Wayne" types, and you'll have a very different prison. From a continuum viewpoint, one might instead argue that people are not "John Wayne" or "not John Wayne." Rather, we each have the capacity for manifesting brutal and degrading behavior. This situation, demanding that guards "control" prisoners, can call forth this behavior. The individual most disposed to manifesting it, does so. Remove that individual, and the next most disposed will arise to assume this role. A STELLA model of this experiment, constructed using a continuous modeling process, did indeed show this result. The conclusion from the model, therefore, is that seeking to screen out "John Waynes" is not likely to be an effective intervention for improving the dynamic equilibrium (in real prisons or simulated ones) between prisoners and guards. Instead, some more fundamental change in the system is required.

A second brief example concerns the extreme positions on abortion taken by members of the pro-life and pro-choice camps. Who would want to be labeled anti-life or anti-choice? Yet that is how some in each camp see the other side. Once a debate becomes polarized in this fashion, it becomes extremely difficult to make any progress in resolving the issues. You're either "for me" or "against me." But, from a continuum standpoint, "us versus them" disappears. For example, even the most ardent pro-choice proponent would never claim it was all right to abort a fetus ten minutes before full-term delivery. And no pro-life adherent believes that the flushing of a live egg due to menstruation really is murder. By inventing these extreme conditions, it becomes clear that the real debate is not black and white. Pro-life people really are pro-choice people under certain circumstances, and pro-choice advocates really subscribe to a pro-life position in some cases. Given this perspective, the real issue is, Where is the common ground? When a piece of protoplasm should be considered to have achieved the status of a viable human life form is not so cut-and-dried after all. In place of "us versus them," there is a continuum.

The development of continuum thinking capability is closely related to the development of generic thinking skills. Both emphasize the ability to recognize the familiar in what appears diverse or distinct. It's the ability to see connections and interdependencies rather than sharp boundaries and disconnections. Many continuous models exist that can be used to develop the sense of continuum. Using these models is a powerful process for building continuum thinking capability.

Skill 7: scientific thinking

The final component of systems thinking that we have identified is scientific thinking. Let me begin by saying what scientific thinking is not. My definition of scientific thinking has virtually nothing to do with absolute numerical measurement. Too often, science is taken to be synonymous with "measuring precisely." To me, scientific thinking has more to do with quantification than measurement. Again, the two are not synonymous. There are very few things that can be measured unambiguously, for instance, length, width, height, concentration, magnitude, and velocity. But think of all the things that cannot be measured precisely: how much wisdom you possess; how nice a person you are; what it feels like to go to a particular high school; how hungry you are; how much you love someone; how much self-esteem you have; how frustrated you feel.

I think most people would agree that all these nonmeasurable things are important. None can be gauged on any absolute numerical scale, but all of them can be quantified. It's simple. Pick a scale—for example, 0-100—and assign a value. Zero means "the absence of." One hundred means "maximum possible amount." Establishing a scale does not mean one can specify exactly what any of these values are in the real system. It means only that one has established a rigorous convention for thinking about the dynamics of the variable. Now one can ask questions like, What keeps self-confidence from rising above 100? Since 100 has been defined as "maximum possible amount," some processes must exist in the real system that prevent this accumulation from overflowing! Having been rigorous (scientific) about the quantification, one can then think rigorously about the dynamics of the variable.

Thinking scientifically also means being rigorous about testing hypotheses. This process begins by always ensuring that students in fact have a hypothesis to test. Once again, in the absence of an a priori hypothesis, the experimentation process can easily degenerate into a video game. People will simply flail away trying to get one of the Super Mario Brothers to the Princess. Having an explicit hypothesis to test before engaging in any simulation activity helps guard against the video game syndrome. The hypothesis-testing process itself also needs to be informed by scientific thinking. People thinking scientifically modify only one thing at a time and hold all else constant. They also test their models from steady state, using idealized inputs to call forth "natural frequency responses." This set of rigorous hypothesis-testing concepts really is at the heart of what I mean by scientific thinking.

The seven-track melee

When one becomes aware that good systems thinking involves working on at least these seven tracks simultaneously, it becomes a lot easier to understand

why people trying to learn this framework often go on overload. When these tracks are explicitly organized, and separate attention is paid to develop each skill, the resulting bite-sized pieces make the fare much more digestible. We've found that explicitly separating these seven tracks, then attending to skill development in each, greatly increases learning productivity.

Summary

The connections among the various physical, social, and ecological subsystems that make up our reality are tightening. There is indeed less and less "away," both spatially and temporally, to throw things into. Unfortunately, the evolution of our thinking capabilities has not kept pace with this growing level of interdependence. The consequence is that the problems we now face are stubbornly resistant to our interventions. To "get back into the foot race," we will need to coherently evolve our educational system along three dimensions: educational process, thinking paradigm, and learning tools. At the nexus of these three threads is a learner-directed learning process in which students will use computer-based learning environments to build their intuition and understanding of complex interdependent systems by participating in virtual reality experiences. One of the principal barriers to this exciting prospect is the currently limited capacity for transferring the systems thinking framework to educators and their students. By viewing systems thinking within the broader context of critical thinking skills, and by recognizing the multidimensional nature of the thinking skills involved in systems thinking, we can greatly reduce the time it takes for people to apprehend this framework. As this framework increasingly becomes the context within which we think, we will gain much greater leverage in addressing the pressing issues that await us in the 1990s. The time is now!

References

- Diehl, E. W. 1990. MicroWorlds Creator 2.0. MicroWorlds, Inc., 47 Third St. #200, Cambridge, MA 02141, U.S.A.
- Draper, F., and M. Swanson. 1990. Learner-Directed Systems Education: A Successful Example. *System Dynamics Review* 6(2): 209-213.
- Meadows, D. H. 1982. Whole Earth Models and Systems. *The CoEvolution Quarterly* (summer): 98-108.
- Peterson, S. 1990. *A User's Guide to STELLAStack*. 2d ed. High Performance Systems, 45 Lyme Rd., Hanover, NH 03755, U.S.A.

- Richardson, G. P. 1982. Problems with Causal-Loop Diagrams. *System Dynamics Review* 2(2): 158-170. Original paper 1976.
- Richmond, B. 1985. *Designing Effective Policy: A Conceptual Foundation*. Thayer School of Engineering, Dartmouth College, Hanover, NH, 03755, U.S.A.
- Richmond, B., S. Peterson, and P. Vescuso. 1987. *An Academic User's Guide to STELLA*. High Performance Systems.
- Roberts, N., D. F. Andersen, R. M. Deal, M. S. Garet, and W. A. Shaffer. 1983. *Introduction to Computer Simulation: A System Dynamics Modeling Approach*. Reading, Mass.: Addison-Wesley.